

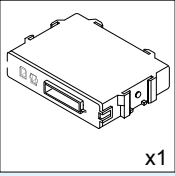
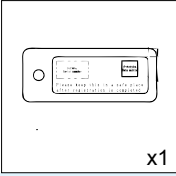
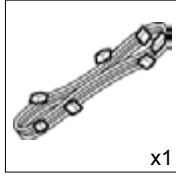
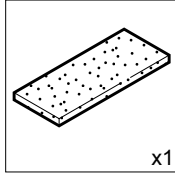
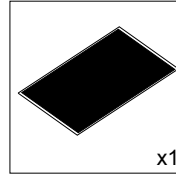
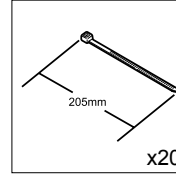
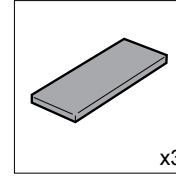

Part #: PT398-76151

Conflicts:

Kit Contents

| | | | | | | |
|--|--|---|---|---|--|---|
| <p>RES+ ECU</p>  <p>x1</p> <p>PT398-00151-AA: RES+ ECU Service Kit</p> | <p>RES+ Key Tag</p>  <p>x1</p> | <p>V9 Harness</p>  <p>x1</p> | <p>Foam Attachment Tape</p>  <p>x1</p> | <p>Protection Sheet</p>  <p>x1</p> | <p>Wire Tie</p>  <p>x20</p> | <p>Foam Tape</p>  <p>x3</p> |
| <p>Window Label</p>  <p>x2</p> <p>PT398-60088</p> | <p>Engine Room Label</p>  <p>x1</p> <p>PT398-00070-EL</p> | <p>RES Key Tag</p>  <p>x2</p> <p>PT398-60086</p> | <p>Nut</p>  <p>x1</p> | <p>RES+ ECU Bracket</p>  <p>x1</p> | <p>RES+ Owner's Guide</p>  <p>x1</p> | <p>RES+ Quick Reference Guide</p>  <p>x1</p> |
| <p>GSM Film Antenna</p>  <p>x1</p> | <p>GSM Antenna Cable</p>  <p>x1</p> | <p>GPS Film Antenna</p>  <p>x1</p> | <p>GPS Antenna Cable</p>  <p>x1</p> | <p>Antenna Template</p>  <p>x1</p> | <p>PT398-76131-AA: RES+ Antenna Service Kit (Includes 10 Wire Ties, 2 Foam Tapes, 1 Protection Sheet and 1 Foam Attachment Tape)</p> | |

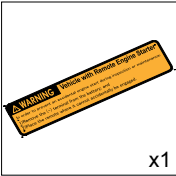
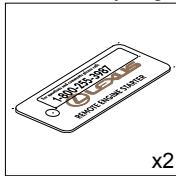
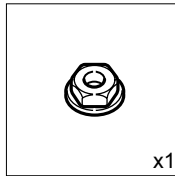
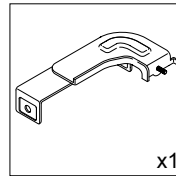
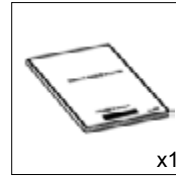
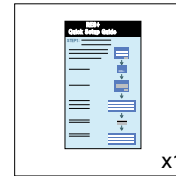
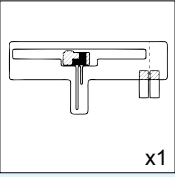
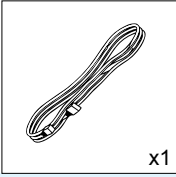
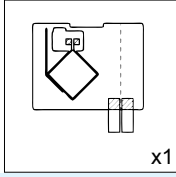
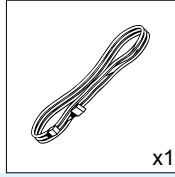
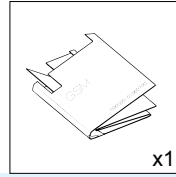
Service Part #s

Recommended Tools

Additional Items

(may be required)

| Item# | Description |
|-------|-------------|
| | |
| | |
| | |
| | |
| | |

Recommended Sequence of Application

| Item# | Description |
|-------|-------------------------------|
| 1 | V2 Glass Breakage Sensor |
| 2 | V9 Remote Engine Starter Plus |
| | |
| | |
| | |

| Personal & Vehicle Protection | Description |
|-------------------------------|--|
| Safety Glasses | |
| Safety Gloves | (Optional) |
| Vehicle Protection | Blankets, Parts Boxes |
| Special Tools | |
| Techstream | Use latest Version on TIS |
| Squeegee | 4" 3M™ Orange Applicator #71607 |
| Installation Tools | |
| Screwdriver | #2 Phillips, Flat Blade Jeweler's |
| Nylon Panel Removal Tool | e.g. Panel Pry Tool #1 Toyota SST# 00002-06001-01 |
| Side Cutters | |
| Torque Wrench | Battery: 48 in•lbf (5.4 N•m), Airbag: 88.5 in•lbf (10 N•m) |
| Ruler | |
| Utility Knife | |
| Tape | Clear, Electrical, Masking |
| Socket | 10mm, extension |
| Pliers | Needle Nose |
| Special Chemicals | |
| Cleaner | VDC Approved Cleaner |
| Glass Cleaner | Household Glass Cleaner |

Table of Contents

I. Preparation 1-3

 1. Table of Contents 2

 2. Wire Routing Overview 3

II. Procedure 4-38

 1. Vehicle Disassembly 4

 2. RES+ ECU Preparation and Installation 11

 3. V9 Harness Installation 13

 4. GPS and GSM Antenna Installation 20

 5. Registration Preparation 28

 6. Registration 29

 7. V9 Harness Installation (Continued) 34

 8. Tags and Labels 37

 9. Complete the Installation 38









III. Checklist 39-41

 1. Accessory Function Checks 39

 2. Vehicle Appearance Check 39

 3. Vehicle Function Checks 40

Legend

-  Do not proceed until process has been completed.
-  Follow steps carefully to avoid damaging the Vehicle or Accessory
-  Use caution to avoid injury.
-  Used in Figures to call attention to specific tools recommended for the process.
-  Highlights a change in installation with respect to previous issue.
-  Indicates that torque is related to safety.
-  Video available; click to play.
-  Wire Tie location and number.
-  Foam Attachment Tape location and number.

Accessory Installation Practice (read before installation)

Care must be taken when installing this accessory to ensure damage does not occur to the vehicle. The installation of this accessory should follow approved guidelines to ensure a quality installation.

These guidelines can be found in the “Accessory Installation Practices” document.

This document covers such items as:

- Vehicle Protection (use of covers and blankets, cleaning chemicals, etc.)
- Safety (eye protection, checking torque procedure, etc.)
- Vehicle Disassembly/Reassembly (panel removal, part storage, etc.)
- Electrical Component Disassembly/Reassembly (battery disconnection, connector removal, etc.)

Please see your Lexus dealer for a copy of this document.

CT 200h RES+
Wire Harness Outline*

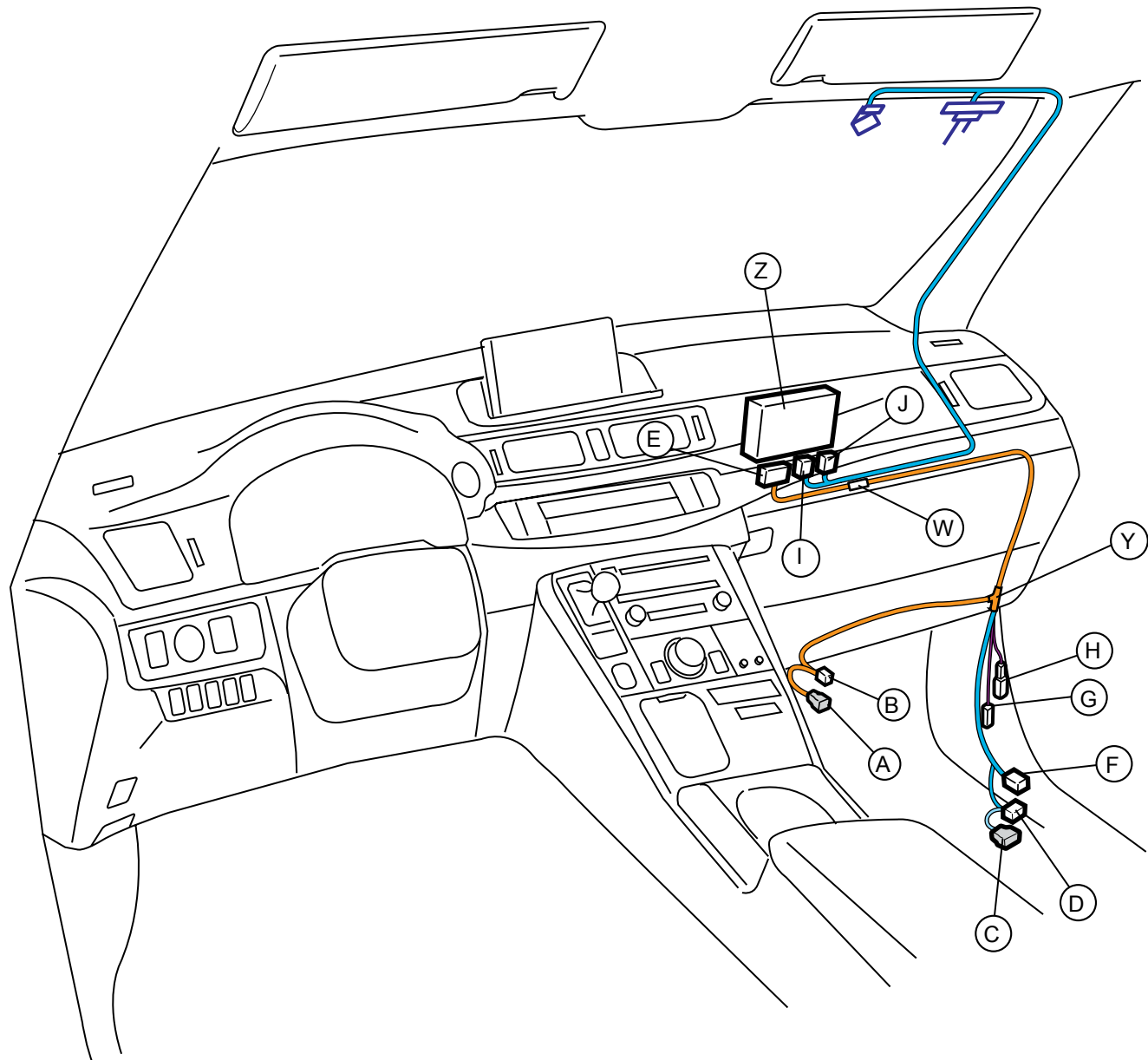

| TVIP | Vehicle | Description |
|------|---------|---------------------------------------|
| A | H34 | 2P White |
| B | H34 | 2P Gray |
| C | JH2 | 12P White |
| D | JH2 | 12P White |
| E | — | 24P White <i>(for RES+ ECU)</i> |
| F | H90 | 8P White |
| G | — | 1P White <i>(for Registration)</i> |
| H | — | 1P White <i>(for Registration)</i> |
| I | — | 1P Blue <i>(for RES+ ECU)</i> |
| J | — | 1P Gray <i>(for RES+ ECU)</i> |
| W | — | White Tape Marker |
| Y | — | Orange Tape Marker |
| Z | — | RES+ ECU |
| | | |
| | | |
| | | |
| | | |
| | | |
| | | |
| | | |
| | | |
| | | |
| | | |
| | | |
| | | |
| | | |
| | | |
| | | |
| | | |
| | | |
| | | |
| | | |
| | | |
| | | |
| | | |
| | | |

*Color of Harness on Overview corresponds with Colored Tape near Connectors on Harness.

Disassembly Overview

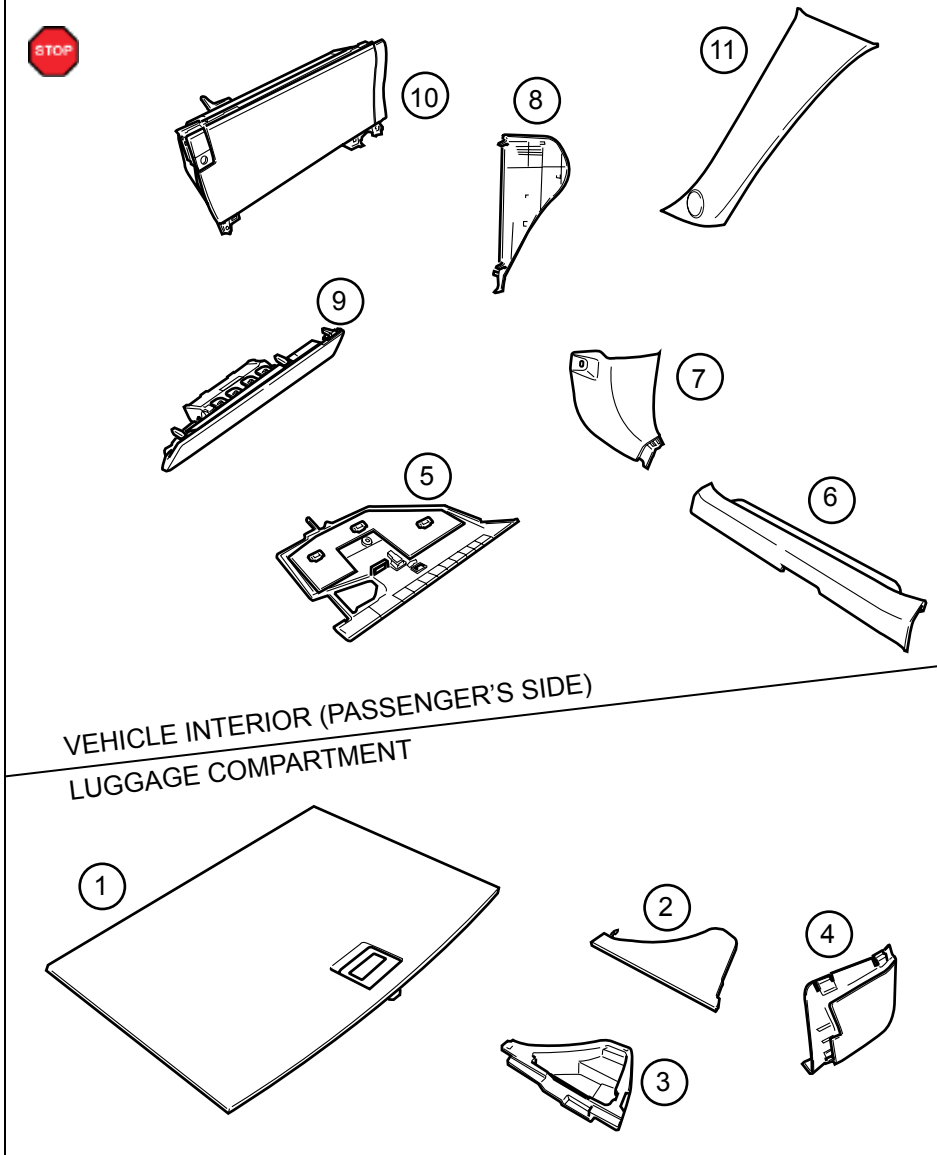

| | |
|---|---|
| 1 | Luggage Board |
| 2 | PS Luggage Side Board |
| 3 | PS Luggage Side Storage Box |
| 4 | Rear Trim |
| 5 | Glove Box Under Cover |
| 6 | PS Step Cover |
| 7 | PS Cowl Cover |
| 8 | PS Dash Side Cover |
| 9 | PS Knee Airbag <i>(Do not disconnect the Airbag connector)</i> |
| 10 | Glove Box |
| 11 | PS A-Pillar Trim |
| | |
| | |
| | |
| | |
| | |
| | |
| | |
|  Disconnect all Corresponding Connectors. | |

1. Vehicle Disassembly.

- a. Place the vehicle in Park with the Parking Brake set.
- b. Remove the Luggage Board.

c. Remove the PS Luggage Side Board.

d. Remove the Luggage Storage Box.

e. Remove the PS Luggage Side Storage Box.

- Remove 1 Nut.

f. Remove the Rear Trim.

- g. Disconnect the Negative Battery Terminal.
- Note the Battery Cable Position as it will be re-installed in the same position.

 **CAUTION:** Do not touch the Positive Terminal.

- h. Dislodge the Glove Box Under Cover.

- i. Disconnect the Vehicle Connector (s).
- Remove 1 Clip.

V9/V2 Add-on ONLY

- j. Disconnect the Microphone's 2P Connector.
- k. Disconnect the Vehicle Connector (s).
 - Remove 1 Clip.

- l. Remove the Passenger's Side Step Cover.

- m. Remove the Passenger's Side Cowl Cover.
 - Remove 1 Nut.

- n. Remove the Passenger's Side Dash Cover.
 - Apply Protection tape on pry area.

- o. Dislodge the Passenger's Knee Airbag carefully.
 - Add Protection tape to center panel.
 - Remove 3 Bolts



CAUTION: Do not disconnect the Vehicle's Connector.

- p. Wrap the Airbag in a Blanket or the like as shown.
- q. Place the Airbag on top of the TVIP box.



CAUTION: Prevent stress on the Airbag Wire.

- r. Remove 2 Screws from the bottom of the Glove Box.
- s. Open the Glove Box.

- t. Dislodge the Glove Box.
 - Remove 2 Screws.

- u. Remove the Glove Box.
 - Disconnect the Vehicle Connector.
 - Remove the Vehicle's Clamp.



CAUTION: Do not remove Glove Box Light.

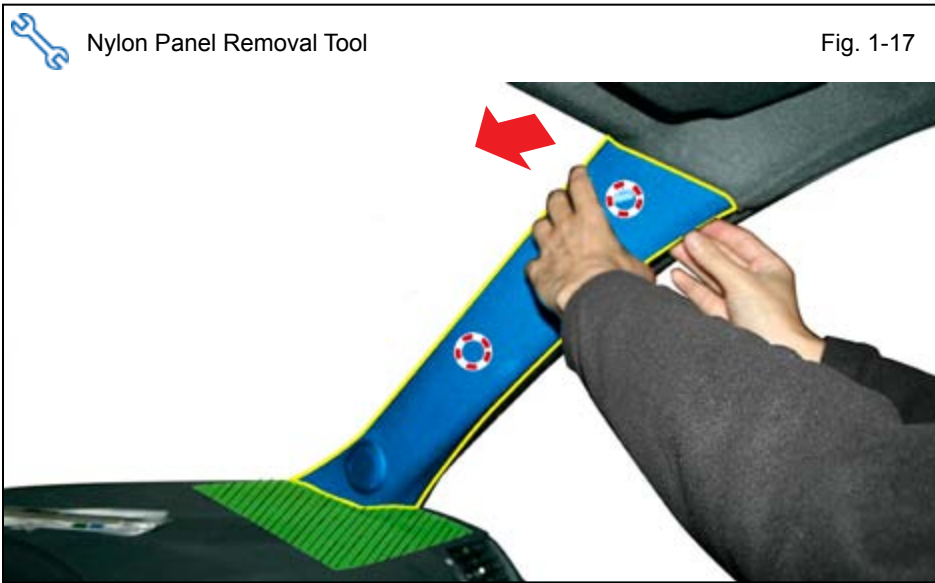

Fig. 1-17

- v. Dislodge the Passenger's side A-Pillar Trim.
 - Apply Protection tape on top of dash and don't remove until the Trim is re-installed.



CAUTION: The trim will only loosen as shown. Trying to remove it without dislodging the internal clip will cause it to break.

If A-Pillar Clip is damaged (i.e. scar) or is removed from the body, replace with a new one. Confirm latest clip P/N on electronic parts catalog.

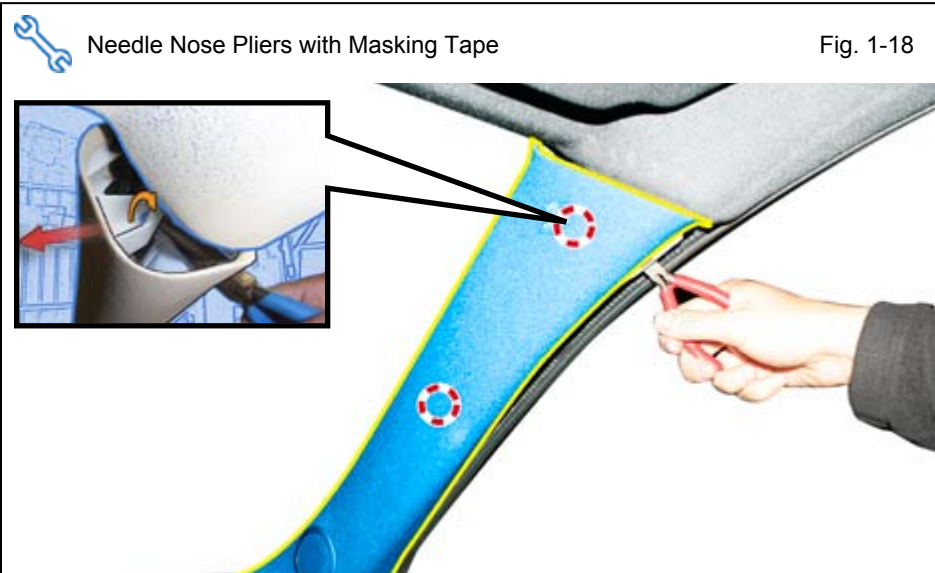

Fig. 1-18

- w. With the jaws of the pliers wrapped in tape to prevent damage, rotate the end of the Clip 90°, and then pull the Trim out to disengage the Internal Clip.



Fig. 1-19



- x. Be careful when disconnecting the Speaker Connector from the bottom of the A-Pillar Trim. (if equipped)
- y. Remove the Passenger's side A-Pillar Trim.

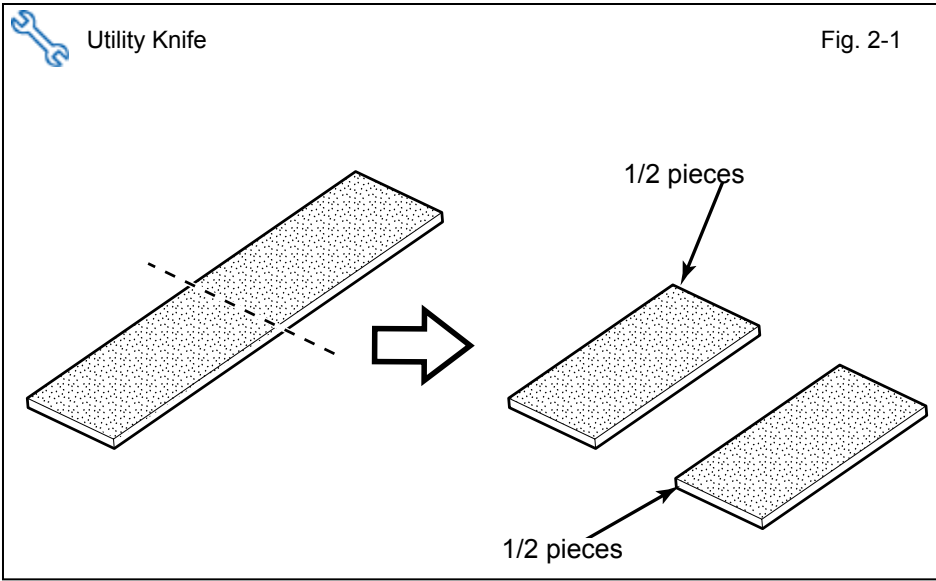

2. RES+ ECU Preparation and Installation.

- a. Cut the 1 Foam tape into 1/2 pieces.

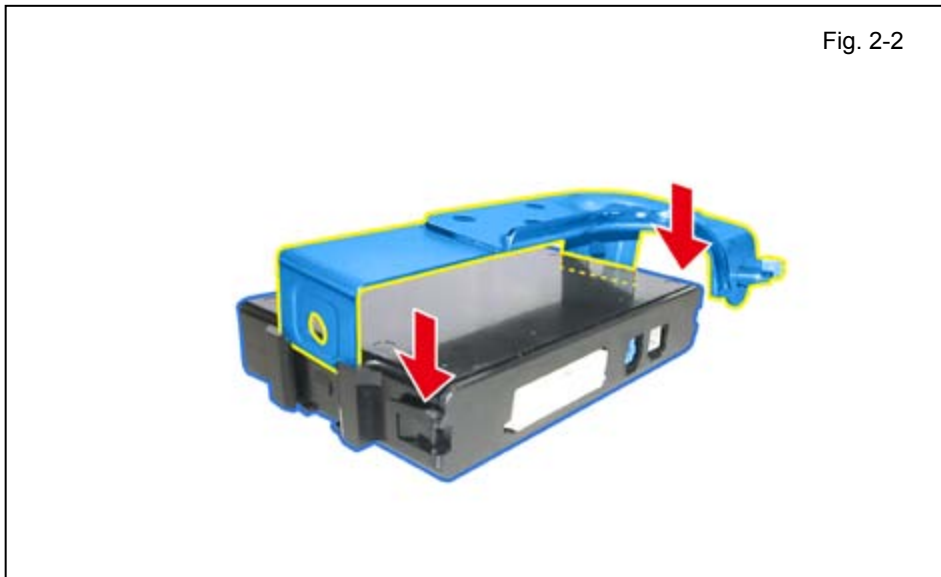

- b. Attach the RES+ ECU Bracket to the RES+ ECU.

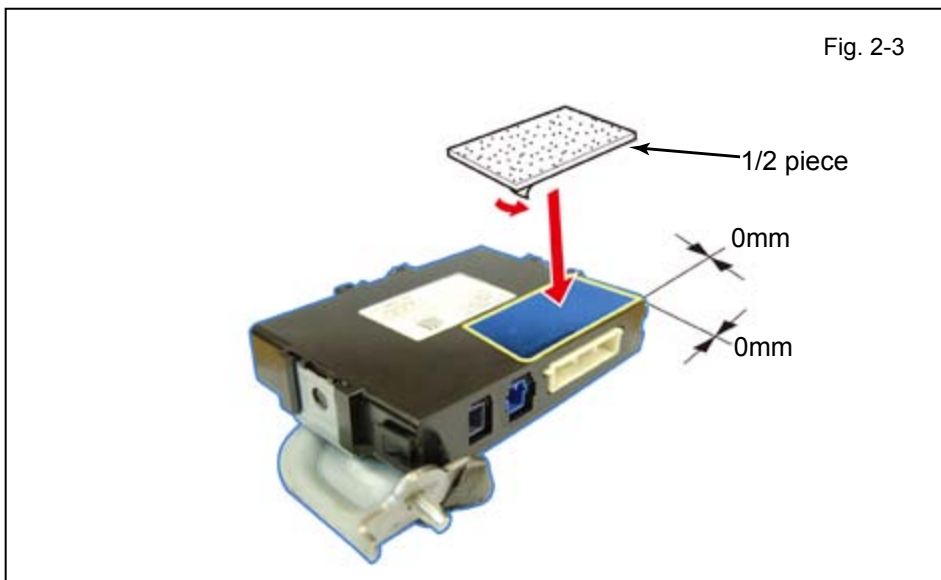

- c. Attach the 1/2 Foam Tape to the RES+ ECU.

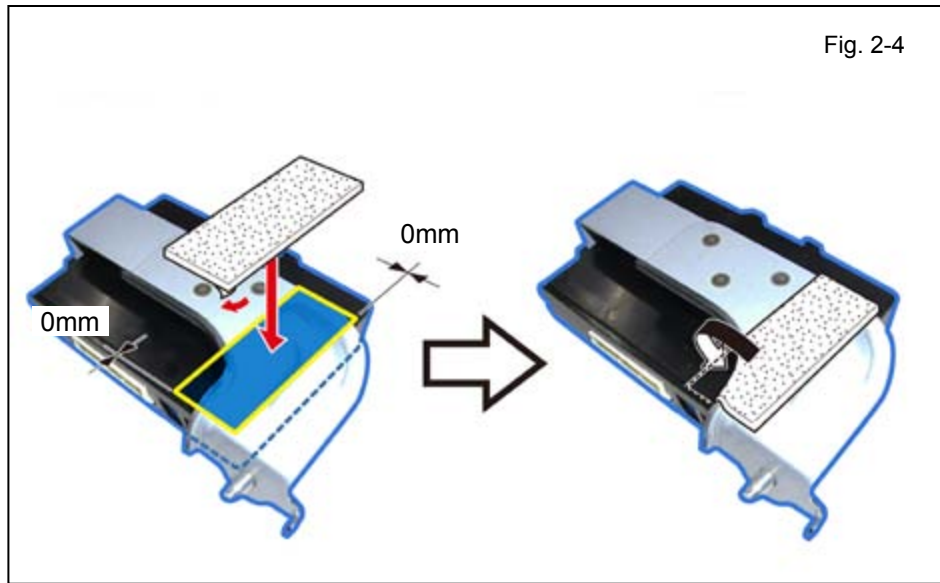

- d. Attach 1/2 Foam Tape to the RES+ ECU Bracket.

- e. Place the RES+ ECU on the Vehicle's Brace in the Glove Box Area.

- f. Install the RES+ ECU using the Nut from the kit.



NOTE: Make sure the Guide Pin is seated correctly and Verify that the Nut is tightened securely.

- e. Route the V9 Harness toward the Passenger's Cowl Area.
- f. Secure the V9 Harness to the Vehicle's Brace with 2 Wire Ties.



- Make sure to secure wire tie# 3 to the Vehicle Brace's 1st Hole from rear side of Vehicle.

- g. Secure the V9 Harness to the Vehicle Harness with 1 Wire Tie.

- h. Secure the V9 Harness to the Vehicle Harness with 1 Wire Tie.
 - Place the V9 Harness's Orange Tape marker parallel to the Vehicle's Brace as shown.

V9 ONLY

- I. Secure the V9 Harness to the Vehicle Harness with 2 Wire Ties.

- m. Secure the 12P Connectors to the Vehicle Harness with 1 Wire Tie.

V9/V2 Add-on ONLY

- n. Secure the V9 Harness to the Vehicle Harness with 1 Wire Tie.
- o. Plug the V9 8P Connector to the V2 8P Connector.

V9/V2 Add-on ONLY

- s. Secure the 12P Connectors to the Vehicle Harness with 1 Wire Tie.



CAUTION: Do not secure the 12P Connectors to the Airbag Harness.

- t. Route the V9 Harness along the Vehicle Harness under the Glove Box Area.
- u. Secure the V9 Harness to the Vehicle Harness with 1 Wire Tie.

- v. Secure the V9 Harness to the Vehicle Harness with 3 Wire Ties.
 - Arrange the V9 Harness Black Tape marker to the Vehicle Harness White (or Black) Tape.

V9 ONLY

- w. Plug the Vehicle's Gray 2P Connector to the V9 White 2P Connector.

V9/V2 Add-on ONLY

- x. Connect the V2 Gray 2P Connector to the V9 White 2P Connector.

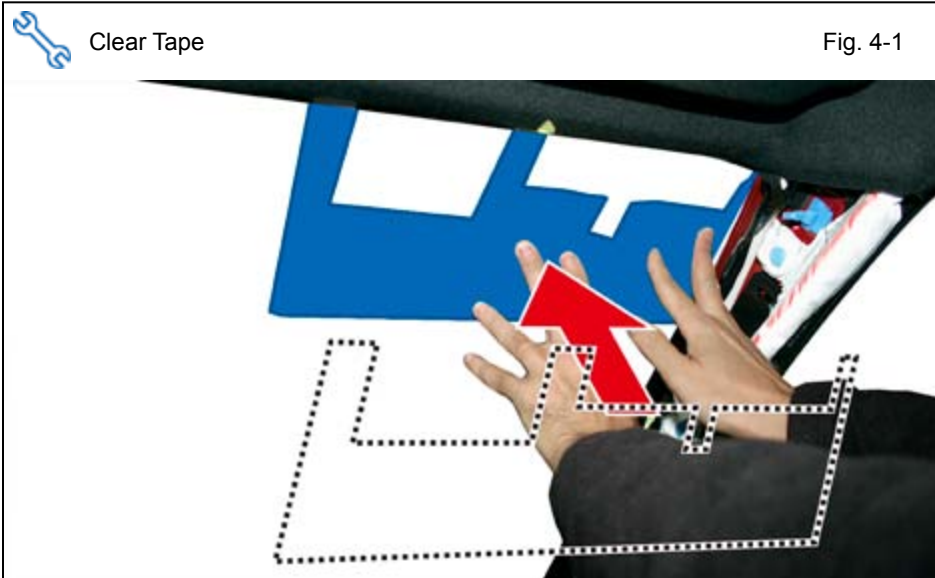

Fig. 4-1

4. GPS and GSM Antenna Installation.

- a. Use Household Glass Cleaner to clean the inside of the Passenger's side Windshield.
- b. Line up the Antenna Template to the edges of the Headliner and A-Pillar on the Passenger's side Windshield.
 - Use clear tape to attach Template to the Windshield.



NOTE: Make sure not to apply tape over areas where the Film Antennas will be placed.

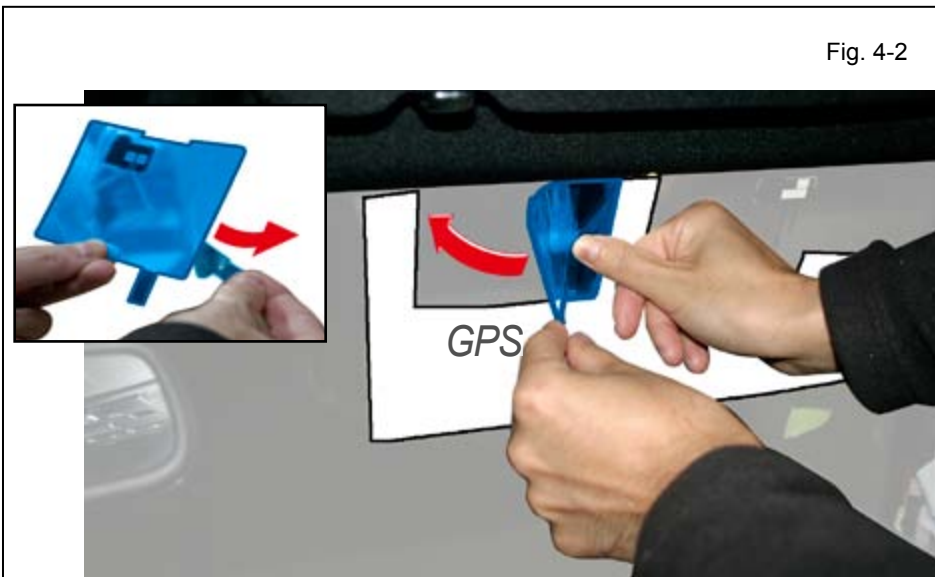

Fig. 4-2

- c. Use the Blue Tab to remove the partial protective backing from the GPS Film Antenna.
- d. Attach the GPS Film Antenna on the specified Template location on the Windshield.



- Line up the Film Antenna to the Headliner edge.

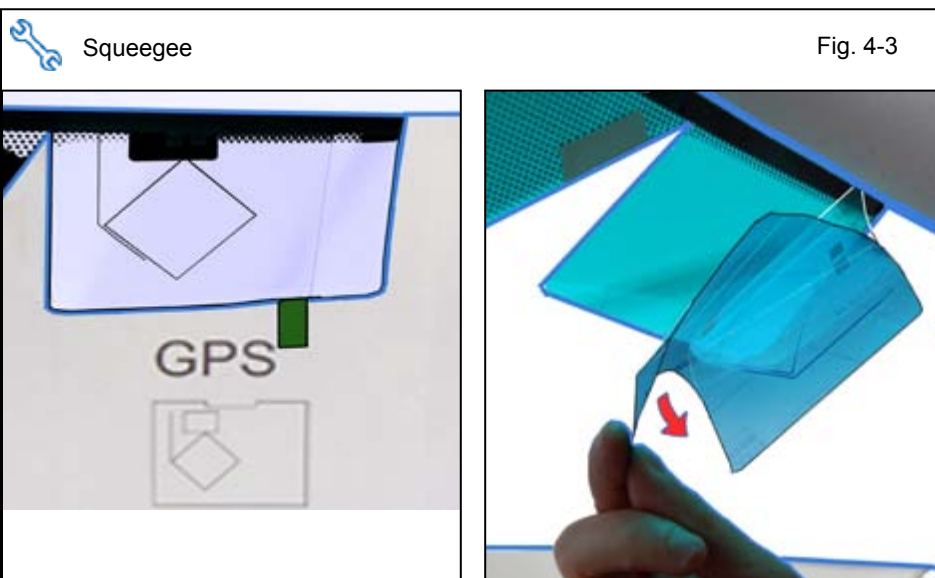

Fig. 4-3

- e. Use the Green Tab to peel off remaining protective backing to attach the whole GPS Film Antenna on the Windshield.



Slowly peel off the protective backing.



NOTE: Make sure to use a squeegee when attaching Film Antenna on the Windshield to eliminate any Air Bubbles.

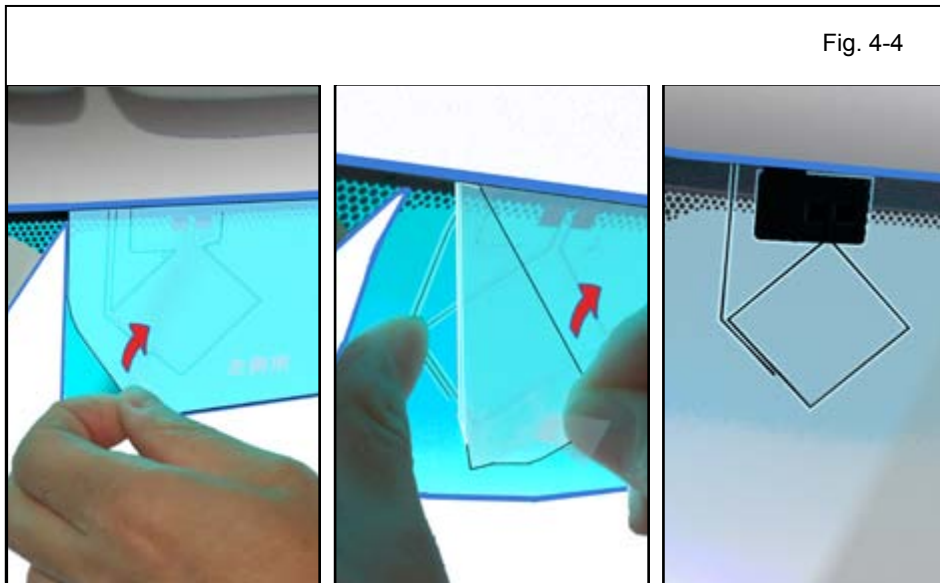

Fig. 4-4

- f. Carefully and Slowly peel off the top protective sticker leaving only the GPS Film Antenna on the Windshield.
- g. Use a soft cloth to press on the Film Antenna for it to fully adhere to the Windshield and to eliminate any Air Bubbles.



CAUTION: Do not use hard tools like spatulas, squeegee, etc., once the top protective film has been removed.



CAUTION: Do not touch the GPS Film Antenna Terminal.



Squeegee

Fig. 4-5

- h. Use no. 1 Tab to peel off the partial protective backing from the GSM Film Antenna.
- i. Attach the GSM Film Antenna on the specified Template location on the Windshield.



- Line up the Film Antenna to the Headliner edge.



NOTE: Make sure to use a squeegee when attaching Film Antenna onto the Windshield to eliminate any Air Bubbles.



Squeegee

Fig. 4-6

- j. Use the no. 2 Tab to peel off remaining protective backing to attach the remaining part of the GSM Film Antenna on the Windshield.



Slowly peel off the protective backing.



NOTE: Make sure to use a squeegee when attaching Film Antenna onto the Windshield to eliminate any Air Bubbles.

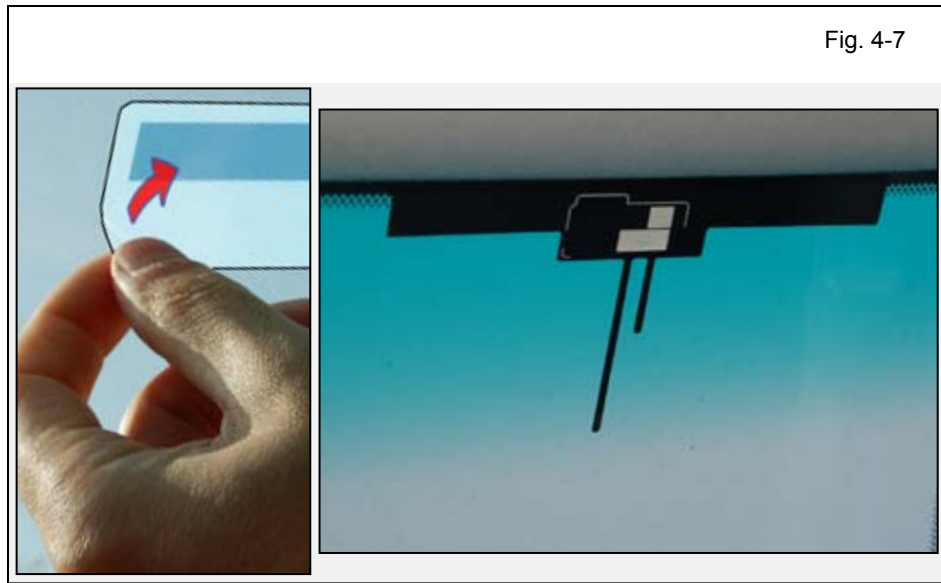

- k. Carefully and Slowly peel off the top Protective sticker leaving only the GSM Film Antenna on the Windshield.
- l. Use a soft cloth to press on the Film Antenna for it to fully adhere to the Windshield and to eliminate any Air Bubbles.



CAUTION: Do not use hard tools like spatulas, squeegee, etc., once the top protective film has been removed.



CAUTION: Do not touch the GSM Film Antenna Terminal.

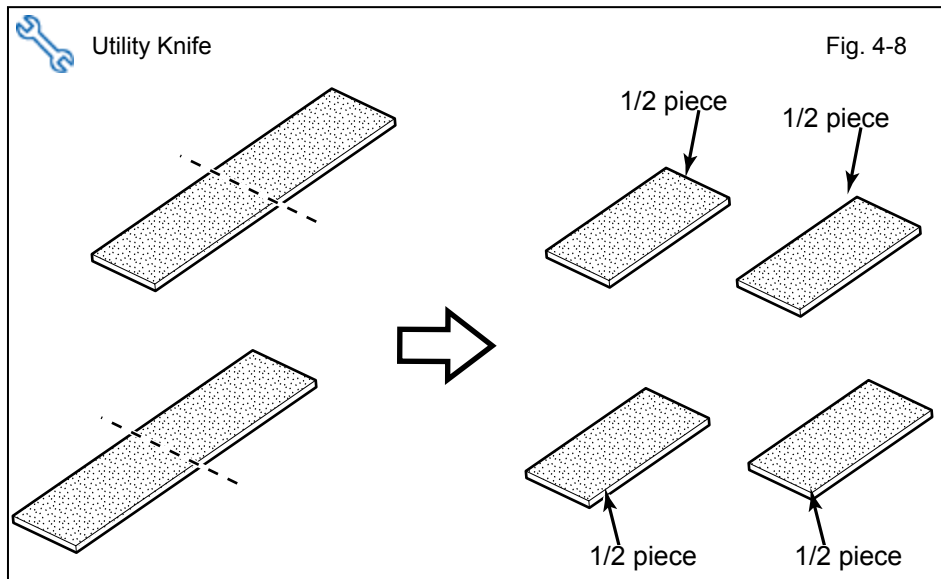

- m. Cut 2 Foam Tapes into four 1/2 pieces.

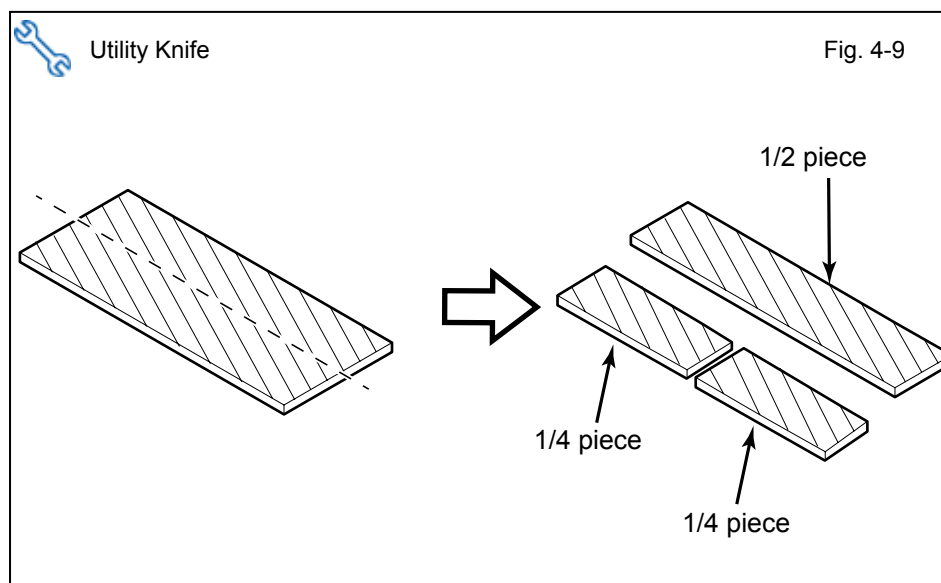

- n. Cut the Protection Sheet into 1/2 piece and two 1/4 pieces.

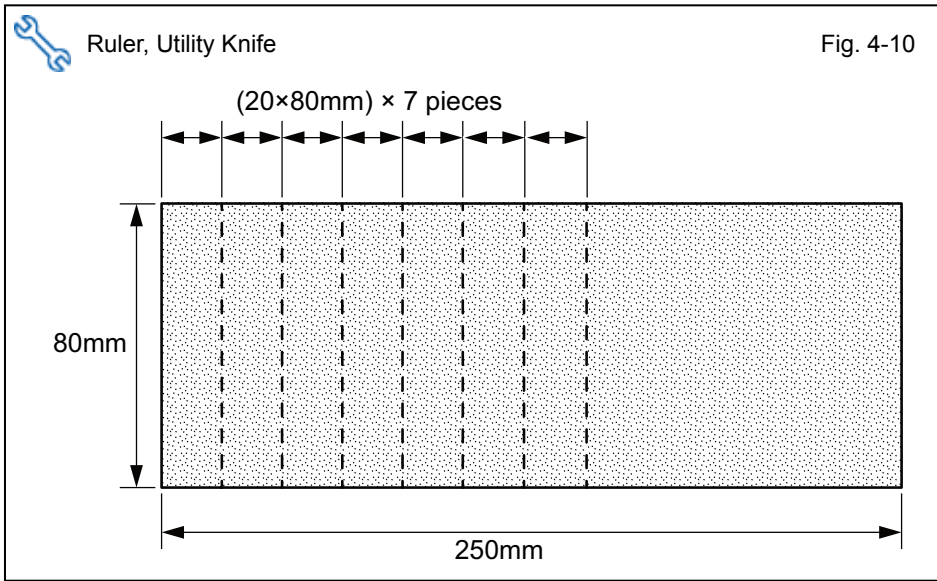

- o. Cut out 7 pieces of 20x80mm size from the Foam Attachment Tape as shown.

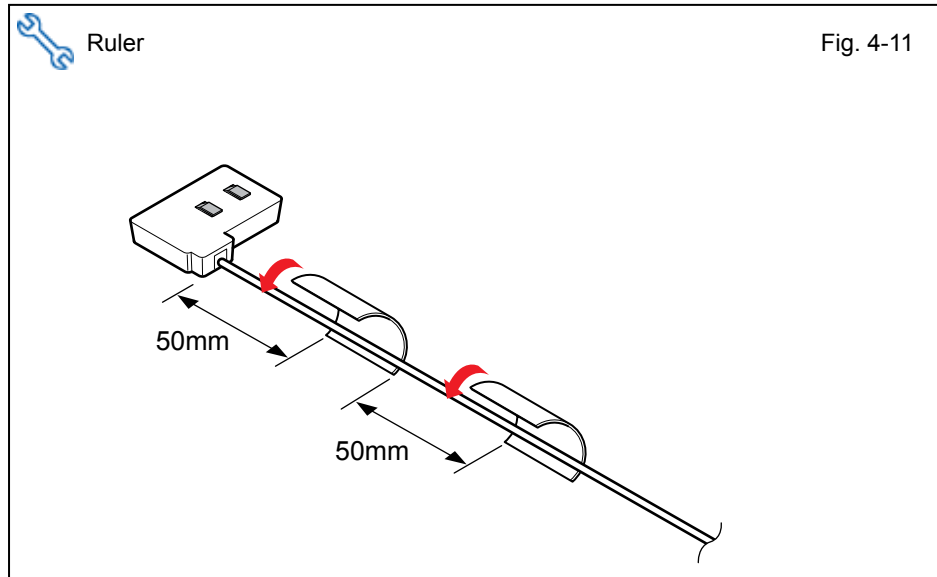

- p. Wrap the GPS Antenna Wire with 1/2 piece of Small Foam tape 50mm away from the GPS Antenna.
- q. Wrap another 1/2 piece of Small Foam tape 50mm away from the first Foam tape.

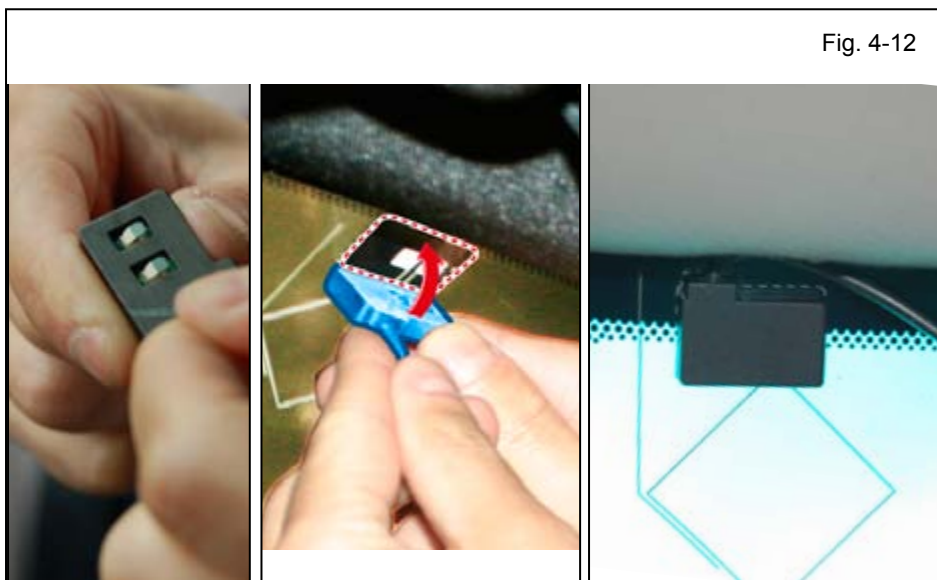

- r. Peel off the protective backing from the GPS Antenna.
- s. Attach the GPS Antenna to the GPS Film Antenna on the Windshield.



NOTE: Make sure to align the GPS Antenna to the broken line guide on the GPS Film Antenna.



CAUTION: Do not touch the Terminal and adhesive face of the GPS Antenna.



CAUTION: Do not re-attach the GPS Antenna.

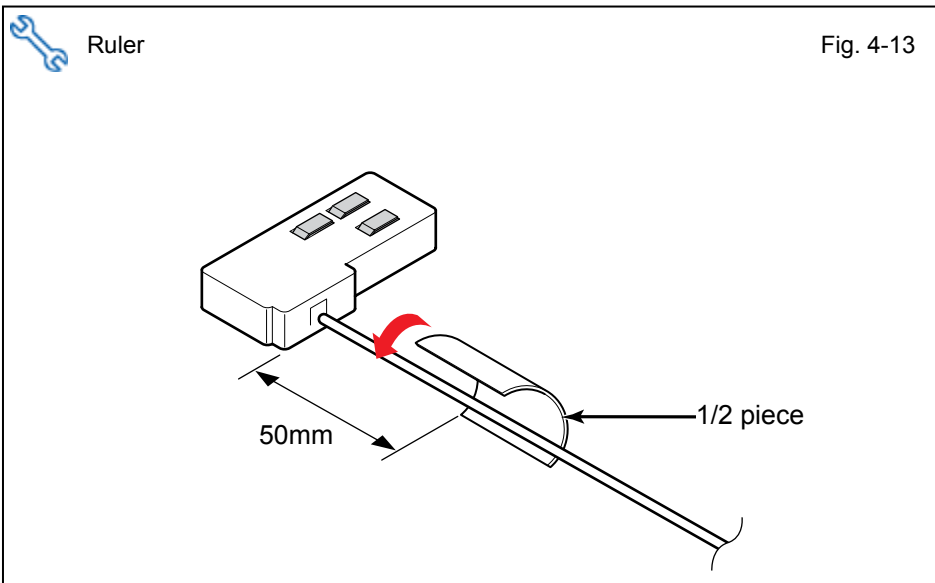

- t. Wrap the GSM Antenna Wire with 1/2 piece of Small Foam tape 50mm away from the GSM Antenna.

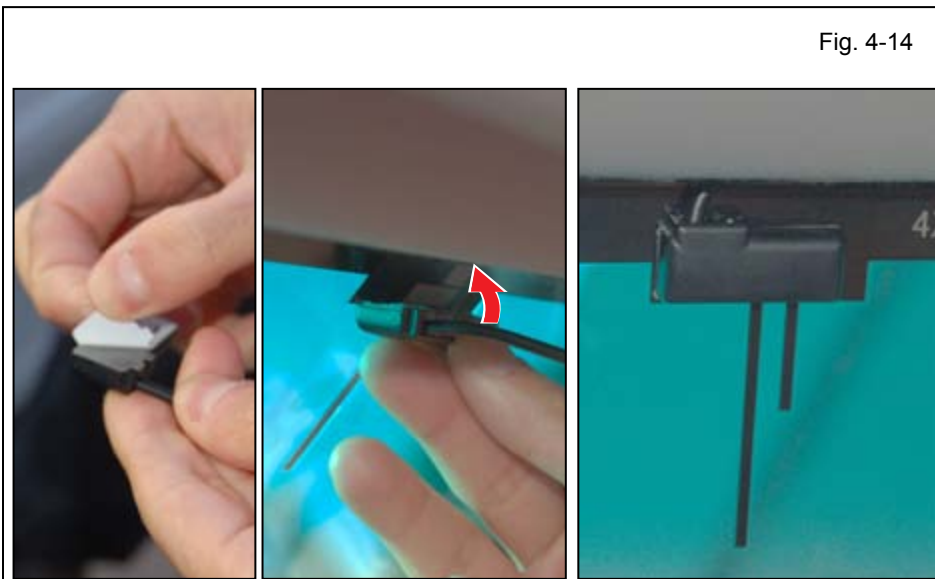

- u. Peel the protective backing off the GSM Antenna.
- v. Attach the GSM Antenna to the GSM Film Antenna on the Windshield.



NOTE: Make sure to align the GSM Antenna to Line guide on the Film Antenna.



CAUTION: Do not touch the Terminal and adhesive face of the GSM Antenna.



CAUTION: Do not re-attach the GSM Antenna.



- w. Tuck both Antenna Wires in between the Headliner and the Windshield routing them toward the Passenger's side A-Pillar area.

- x. Route the Antenna Wires along the bottom of the Vehicle Harness securing it with 6 (20x80mm) pieces of Foam Attachment tape.



NOTE: Do not secure Antenna Wires to Vehicle's Drain Hose or Airbag.

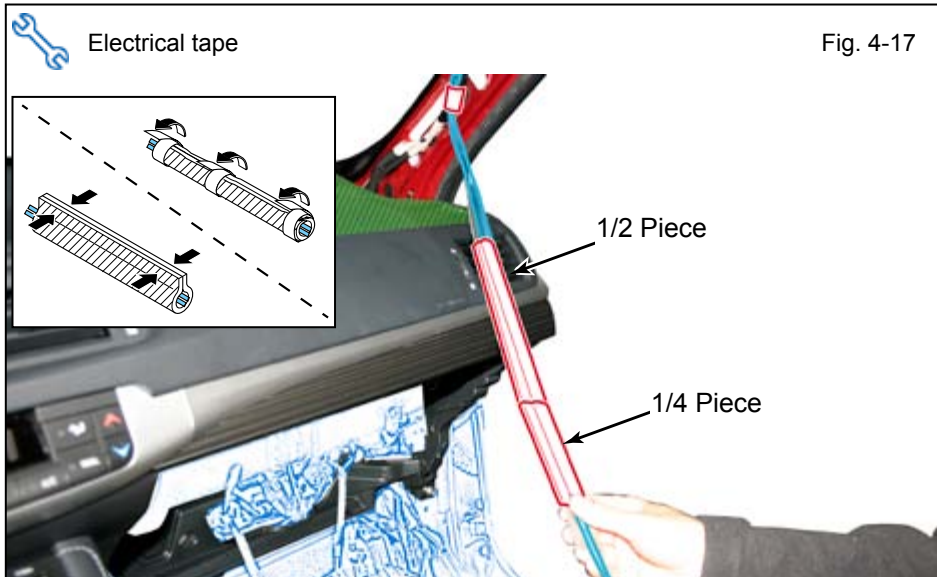

- y. Wrap both Antenna Wires starting from the bottom of the A-Pillar using the 1/2 pc. and 1/4 pc. of Protection Sheet.
- z. Secure the Protection Sheet with Electrical tape.

- aa. Continue routing the Antenna Wires down towards the Glove box Area.

- ab. Secure the Antenna Wires to the Vehicle Harness using 1 (20x80mm) piece of Foam Attachment tape.



NOTE: Do not secure Antenna Wires to Vehicle's Drain Hose.

- ac. Secure the Antenna Wires to the Vehicle Bracket using 1 Wire Tie.

- ad. Secure the Antenna Wires to the V9 Harness using 2 Wire Ties.



- ae. Wrap the Antenna Wires that routes over the Vehicle Bracket area with 1/4 piece of Protection sheet and secure with Electrical tape.

af. Connect both the GPS and GSM Antenna Connectors to the RES+ ECU.

ag. Secure the Antenna Wires and V9 Harness to the Vehicle Harness using 1 Wire Tie.

ah. Bundle up the excess Antenna Wires and use electrical tape to secure them together.

ai. Secure the Bundled Antenna Wires to the Vehicle Harness using 2 Wire Ties.

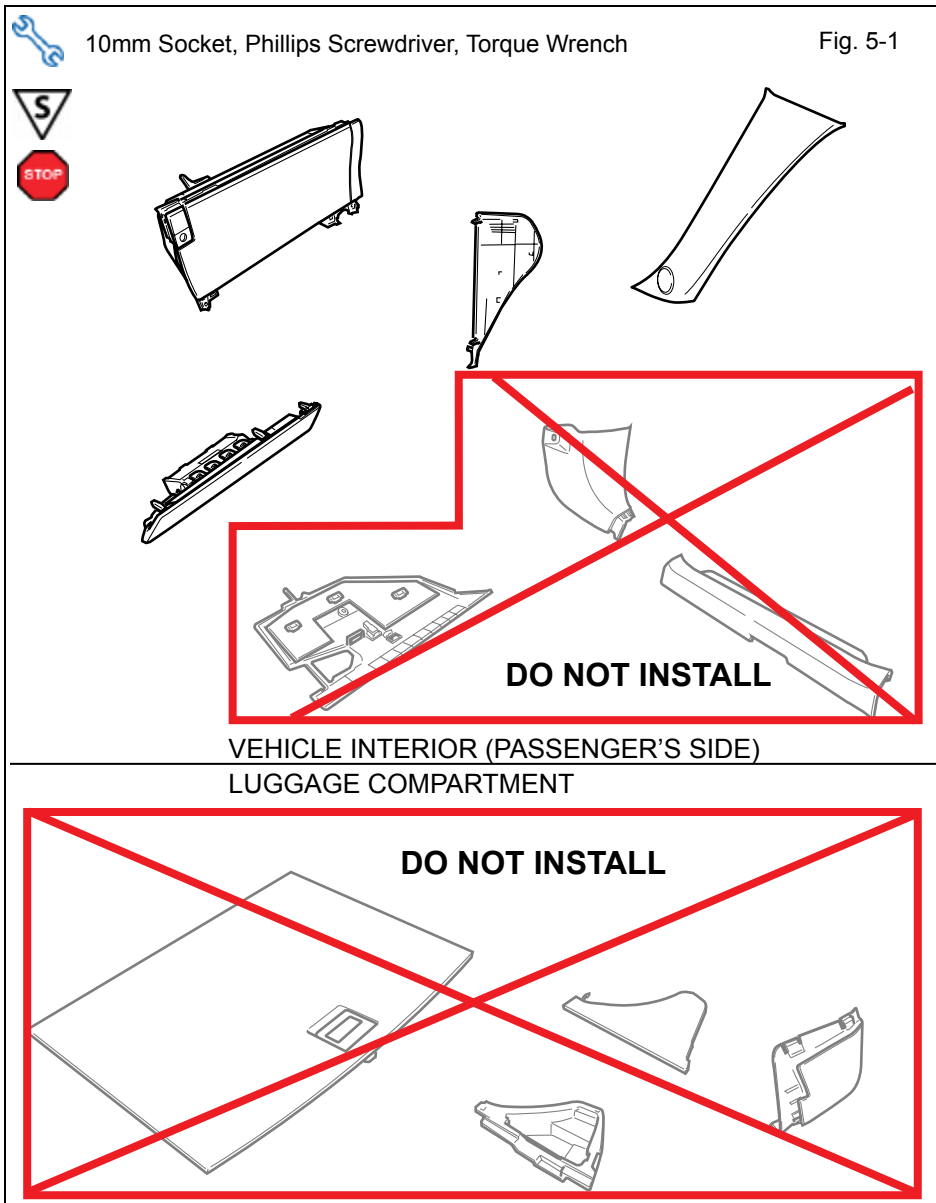

5. Registration Preparation.

- a. Partially reassemble the Vehicle.



NOTE: When reinstalling Knee Airbag, make sure to tighten the Bolts to 88.5 in•lbf (10 N•m).



VERIFY: That all Connectors are reconnected.



VERIFY: That panels fit together properly, with no uneven gaps.

- b. Verify that the Short Pin is installed.
 - If not install now.

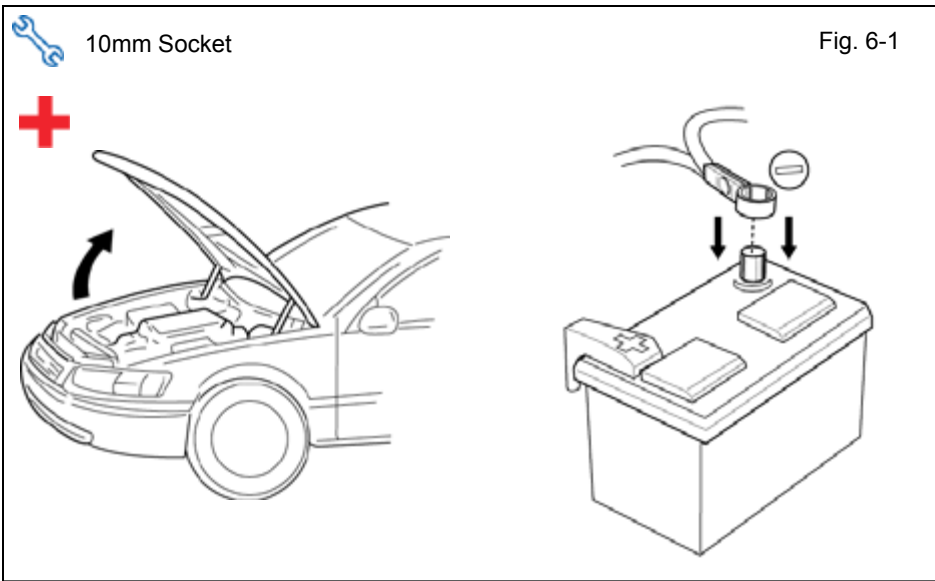

6. Registration.

- a. Open the Hood.
- b. Temporarily reconnect the Negative Battery Cable.

+ **CAUTION:** Do not touch the Positive Terminal.

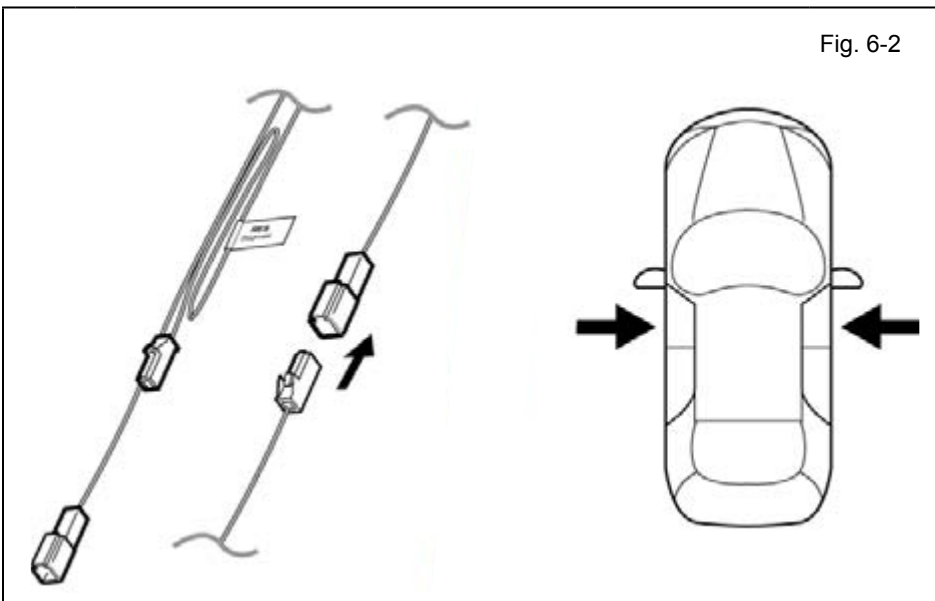

- c. Locate the 1P RES Diagnostic Connectors in the Passenger Cowl Area and connect them.

NOTE: Once connected you will have 10 minutes to complete this section, steps d–aa.

- d. Close all doors.

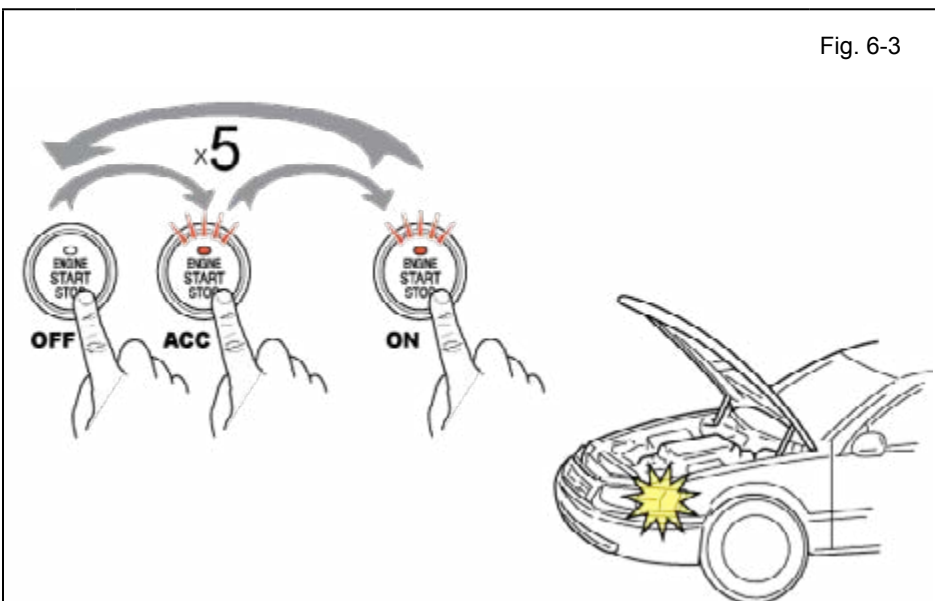

- e. Place the Vehicle in Park (P) position.
- f. Cycle the “ENGINE START STOP” Button from OFF to ON 5 times.

NOTE: One cycle consists of: OFF → Accessory → ON
This is equivalent to pressing the “ENGINE START STOP” Button 14 times.

LOOK: For the Hazard Lights to Flash Once.

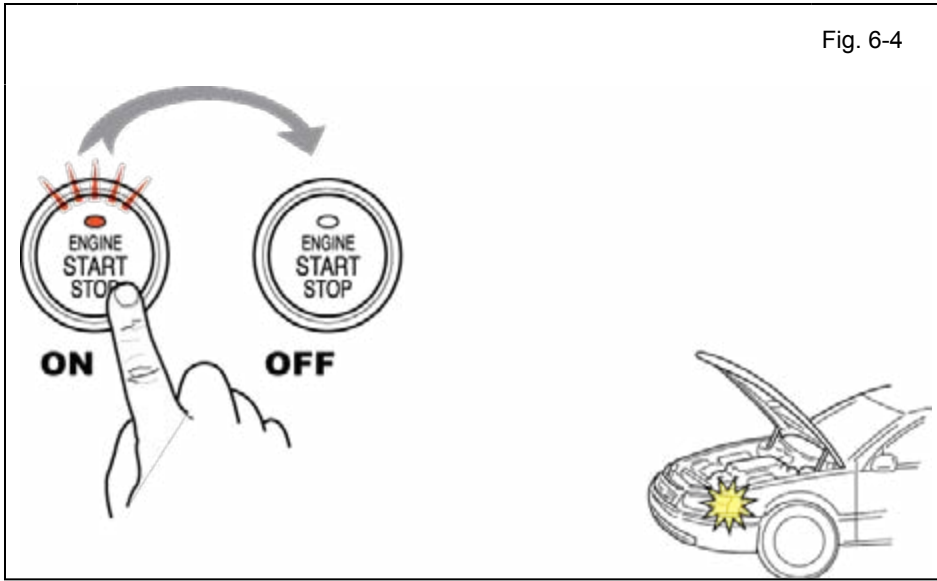

- g. Start the Engine.
- h. After 10 seconds stop the Engine.

LOOK: For the Hazard Lights to Flash Once.

IF THIS PROCEDURE FAILED

The Hazard Lights flash Three Times.

- Disconnect the V9 Harness's 1P RES Diagnostic Connectors.
- Start again from step c.

- i. Connect the Techstream Notebook to the Vehicle's Diagnostic Port.
- j. With the Smart Key in your possession, press the "ENGINE START STOP" Button twice to select the Ignition "ON" position.

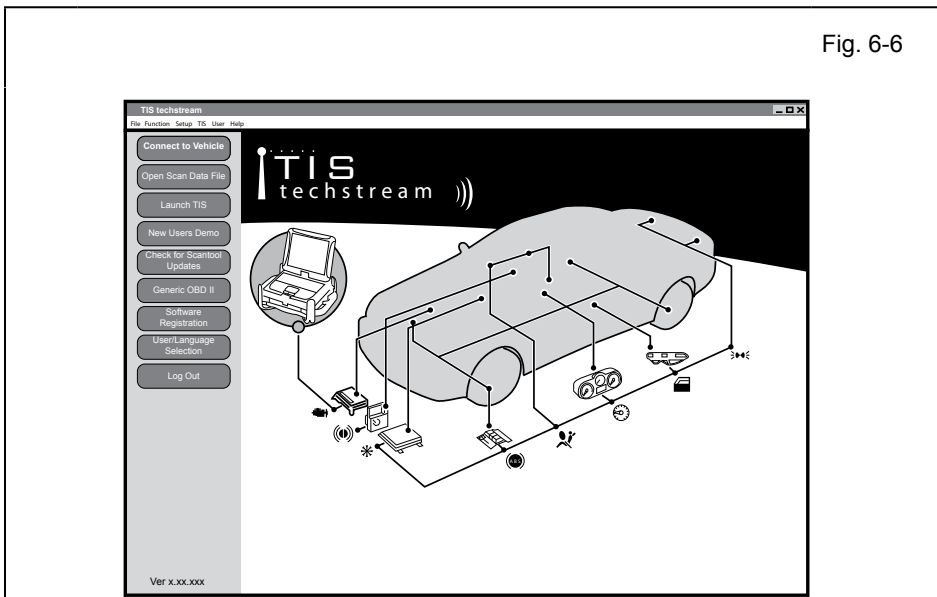

- k. Start the TIS Techstream Application by clicking on the shortcut located on the Desktop.
- l. Click "Connect to Vehicle."

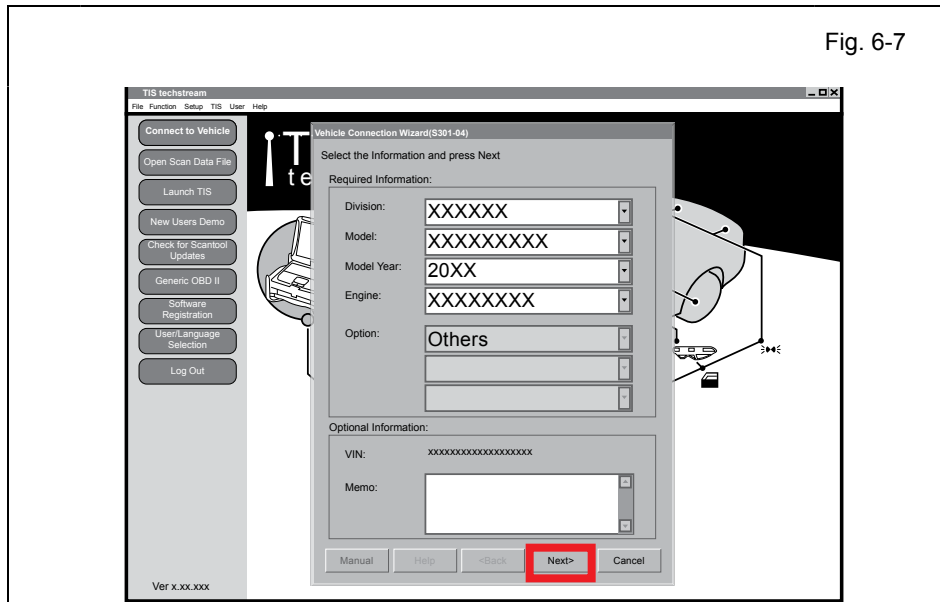

Fig. 6-7

- m. Confirm that the information displayed on the Vehicle Connection Wizard is correct for the vehicle. If not verify that the Techstream is properly connected.
- n. Select “Others.”
- o. Click “Next>.”

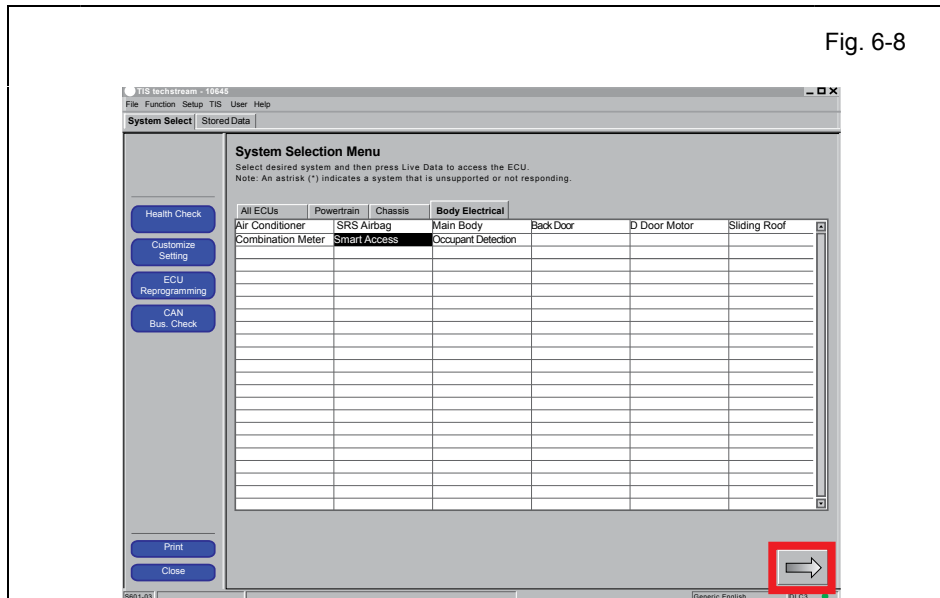

Fig. 6-8

- p. Select “Smart Access.”
- q. Click .

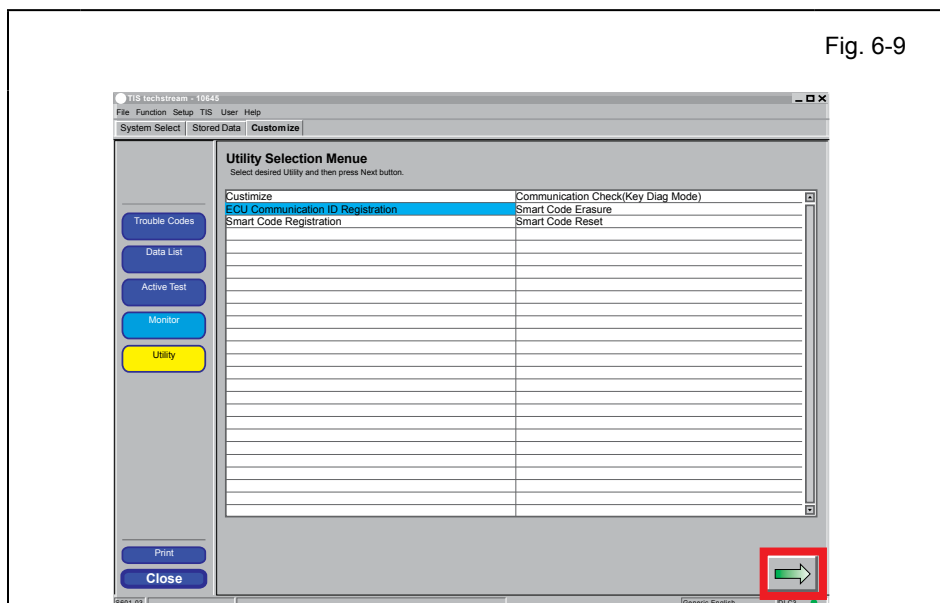

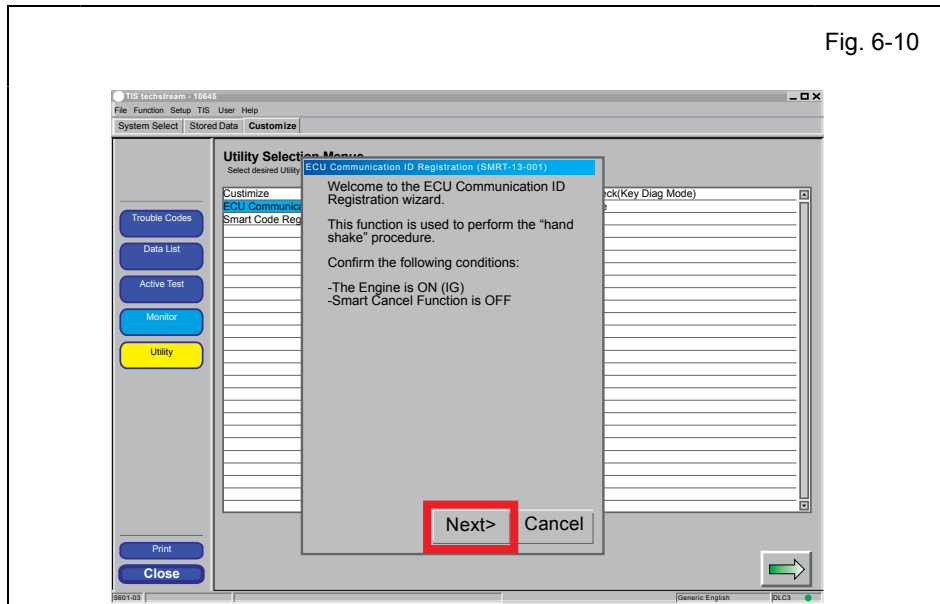
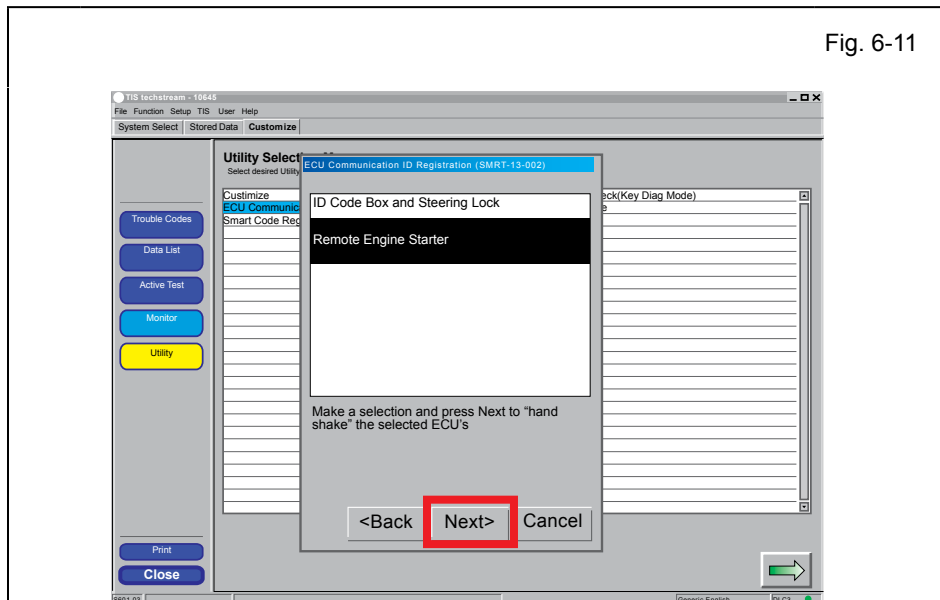

Fig. 6-9

- r. Click on “Utility.”
- s. Select “ECU Communication ID Registration.”
- t. Click .



u. Click "Next>."



v. Select "Remote Engine Starter."

w. Click "Next>."

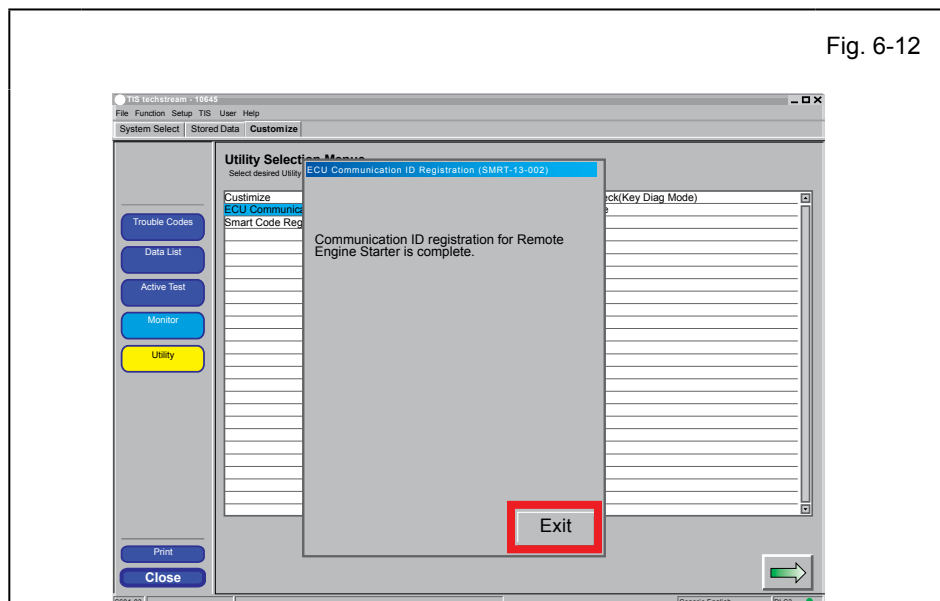

CONFIRM: That the ECU Communication ID was completed successfully.

x. Click "Exit."

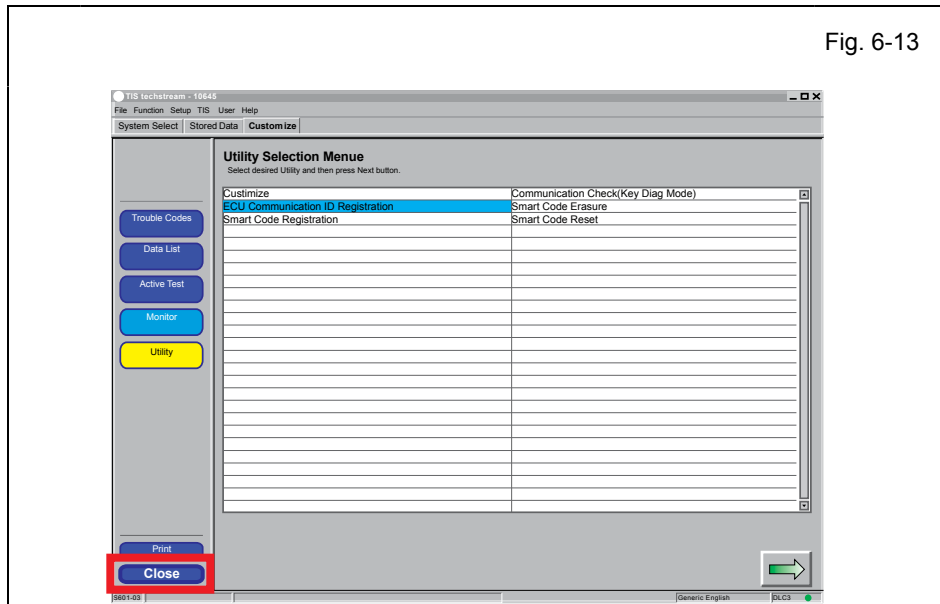

y. Click 

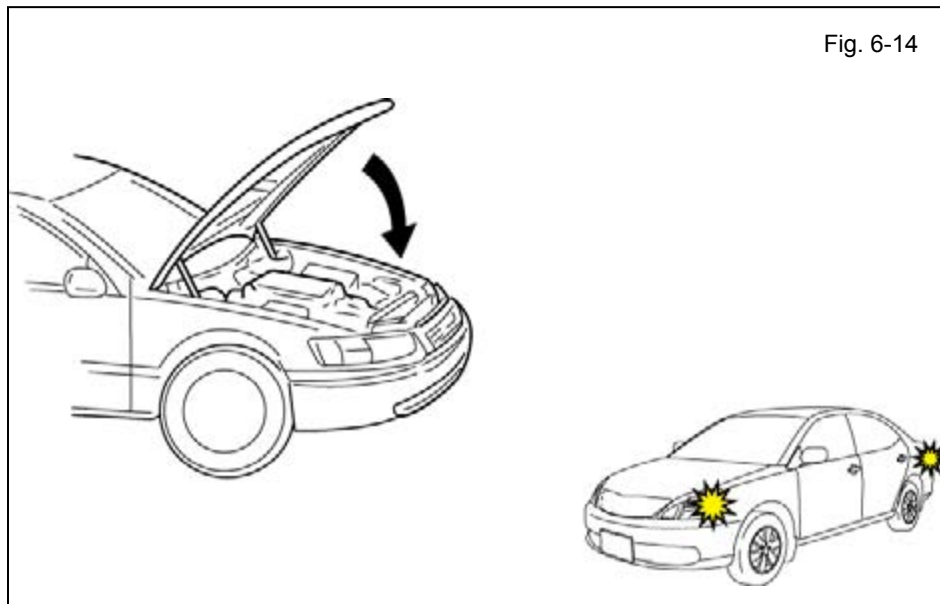

z. Exit the vehicle, then Close the Hood.



LOOK: For the number of times the Hazard Lights flash.

aa. The Hazard Lights flash twice, registration completed.

IF THIS PROCEDURE FAILED

If the Hazard Lights flash 3 Times.

- Disconnect the 1P RES Diagnostic connector and start again from step c.

If the Hazard Lights flash 4 Times.

- Check connection between GPS Antenna and RES+ ECU.
- Disconnect the 1P RES Diagnostic connector and start again from step c.

If the Hazard Lights flash 5 Times.

- Move vehicle to an area with good cellular reception.
- Disconnect the 1P RES Diagnostic connector and start again from step c.

If the Hazard Lights flash 6 Times.

- Check connection between GSM Antenna and RES+ ECU.
- Disconnect the 1P RES Diagnostic connector and start again from step c.

- ab. After a successful Registration, disconnect the 1P RES Diagnostic Connectors.
- ac. Using Electrical Tape secure the RES Diagnostic Connectors and Harness to the Vehicle Harness.

7. V9 Harness Installation. (Continued)

- a. Open the Trunk Lid.
- b. Disconnect the Negative Battery Terminal.

 **CAUTION:** Do not touch the Positive Terminal.

V9 ONLY

- c. Connect the V9 Gray 2P Connector to the Vehicle's Gray 2P Connector.
 - Reinstall the Vehicle's Clamp

V9 ONLY

- d. Secure the 2P Connectors to the Vehicle Harness with 1 Wire tie.



- Make sure to secure the 2P Connectors as shown.

V9/V2 ADD-ON

- e. Connect the Microphone's 2P Connector to the V2 Harness 2P Connector.

- f. Connect the V9 Gray 2P Connector to the Vehicle's Gray 2P Connector.
- Reinstall the Vehicle's Clamp

- g. Secure the 2 2P Connectors to the Vehicle Harness with 1 Wire tie.



- Make sure to secure the two 2P Connectors as shown.

- h. Reinstall the Glove Box Under Cover.

8. Tags and Labels.

- a. Using VDC approved cleaner and cleaning method, clean the area indicated on the underside of the Hood.
- b. Attach the Engine Room Warning Label.



CAUTION: Do not touch the adhesive surface.

- c. Attach the Key Tag.

REPEAT: steps c with the other Smart Key.

- d. Attach the RES+ Key Tag with serial number to the Large Key Ring.

- e. Use Household Glass Cleaner to clean the inside of the Front Door Window.
- f. Use a piece of Clear Tape to lift the Label off its protective backing.



CAUTION: Do not touch the adhesive surface.

- g. Use a piece of Clear Tape to attach the Label as shown.



NOTE: Make sure to Align the Label according to Etching or Other Label.

REPEAT: steps e-g with the other Window.

9. Complete the Installation.

- a. Position the Negative Battery Cable at the original factory position and torque the nut.



Torque: 5.4 N•m (48 in•lbf)



CAUTION: Do not touch the positive terminal.

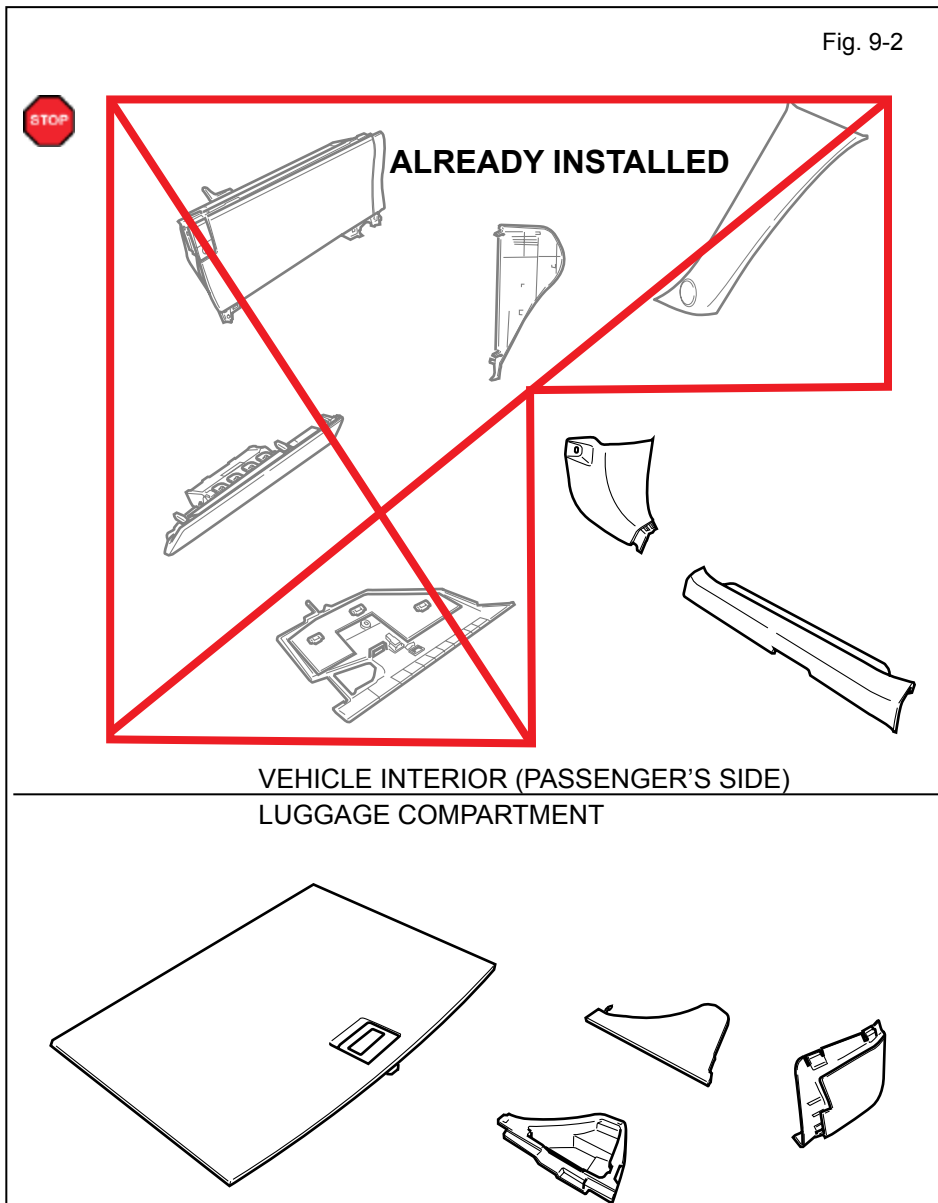

- b. Finish reassembling the Vehicle.



VERIFY: That panels fit together properly, with no uneven gaps.



VERIFY: That all Connectors are plugged in.

- c. Clean up and Remove trash.
- d. Sealed in its protective bag, place the Owner's Manual in the Glove Box.

Accessory Function Checks

Close the hood, enter the vehicle and close all doors. Place the shift lever in the “P” (Park) position, set the parking brake and make sure the Vehicle is off.

| Perform | | Look For |
|---------|---|---|
| 1 | Press the remote control’s lock button twice within 2 seconds, then press and hold the lock button for 3 seconds. | The hazard lights flash after 3 seconds. The engine starts. The hazard lights flash repeatedly for 10 seconds. |
| 2 | With the engine running, pull the hood release handle. NOTE: <i>Wait 30 seconds before pulling the hood release handle for the security alarm to trigger.</i> | The engine stops. The hazard lights flash once. The security alarm triggers. (Only if equipped with OE Factory Alarm, not Genuine Accessory alarm, and only if armed) |

Vehicle Appearance Check

| Perform | | Look For |
|--------------------------|--|---|
| <input type="checkbox"/> | After accessory installation and removal of protective cover(s), perform a visual inspection of the vehicle. | Ensure no damage (including scuffs and scratches) was caused during the installation process. (For PPO installations, refer to TMS Accessory Quality Shipping Standard.) |









Vehicle Function Checks

| Function | Function |
|----------|----------|
|----------|----------|

Enter the Vehicle

| | |
|---|-------------------------------|
| <input type="checkbox"/> Dome/Courtesy Lights | <input type="checkbox"/> Horn |
|---|-------------------------------|

Start the Vehicle

| | |
|---|---|
| <input type="checkbox"/> Starter | <input type="checkbox"/> Gauges |
| <input type="checkbox"/> Check Engine Light <i>If the warning light remains on, it may indicate a system malfunction.</i>  | <input type="checkbox"/> ABS Light (if equipped) <i>If the warning light remains on, it may indicate a system malfunction.</i>  |
| <input type="checkbox"/> Lamp Failure Sensor <i>If the warning light remains on, it may indicate a system malfunction.</i>  | <input type="checkbox"/> Track/Skid Control Light (if equipped) <i>If the warning light remains on, it may indicate a system malfunction.</i>  |
| <input type="checkbox"/> Seat Belt Warning Light <i>If the warning light remains on, it may indicate a system malfunction.</i>  | <input type="checkbox"/> Tire Pressure Monitoring System (TPMS) <i>Prior to TPMS activation and Pre-delivery Service (PDS) of the Vehicle the TPMS light will blink when IG is turned on.</i> <i>After TPMS activation and PDS of the Vehicle the TPMS light will illuminate for a few seconds and go off when IG is turned on.</i>  |
| <input type="checkbox"/> Air Bag Warning Light <i>If the warning light remains on, it may indicate a system malfunction.</i>  | |
| <input type="checkbox"/> Cruise Control Light (if equipped)  | |

Using a Mirror or Assistant check the following.

| | |
|--|---|
| <input type="checkbox"/> Trunk/Tailgate/Bed Lights (if equipped) | <input type="checkbox"/> Tail Lights |
| <input type="checkbox"/> Brake Lights | <input type="checkbox"/> Daytime Running Lights (if equipped) |
| <input type="checkbox"/> Backup Lights | <input type="checkbox"/> Marker Lights |
| <input type="checkbox"/> Clearance Sonar (if equipped) | |

Stop the Engine, Place the Vehicle's IG in the ON position.

| | |
|---|--|
| <input type="checkbox"/> Hazard Lights | <input type="checkbox"/> Turn Signal Lights |
| <input type="checkbox"/> Head Light | <input type="checkbox"/> Fog Lights (if equipped) |
| <input type="checkbox"/> High Beams | <input type="checkbox"/> Accessory Controls/Illumination (if equipped) |
| <input type="checkbox"/> Power Side Mirrors (if equipped) | <input type="checkbox"/> Convenience Memory Settings (if equipped) |
| <input type="checkbox"/> Power Sliding Door (if equipped) | <input type="checkbox"/> Rear Sunshade (if equipped) |

CHECKLIST – these points **MUST** be checked to ensure a quality installation.

REMOTE ENGINE STARTER PLUS (RES+)

| Function | | Function | |
|--------------------------|--|--------------------------|---|
| <input type="checkbox"/> | Front Wiper/Washer | <input type="checkbox"/> | Rear Wiper/Washer (if equipped) |
| <input type="checkbox"/> | Power Sun/Moon Roof (if equipped) | <input type="checkbox"/> | Rollover Side Curtain Air Bag Switch (RSCA) (if equipped) |
| <input type="checkbox"/> | Clock (if equipped) | <input type="checkbox"/> | Navigation System (if equipped) |
| <input type="checkbox"/> | Audio/Video (if equipped) | <input type="checkbox"/> | USB Connections (if equipped) |
| <input type="checkbox"/> | Steering Wheel Audio Control (if equipped) | <input type="checkbox"/> | HVAC |
| <input type="checkbox"/> | Front Windshield Defogger (if equipped) | <input type="checkbox"/> | Rear Window Defogger (if equipped) |
| <input type="checkbox"/> | Side Mirror Defogger (if equipped) | <input type="checkbox"/> | Accessory Power Socket (if equipped) |
| <input type="checkbox"/> | Massage Seats (if equipped) | <input type="checkbox"/> | Heated/Vented Seats (if equipped) |

| | | | |
|--------------------------|-------------------------------|--------------------------|--------------------------|
| <input type="checkbox"/> | Glove box Light (if equipped) | <input type="checkbox"/> | Passenger Side Foot Lamp |
|--------------------------|-------------------------------|--------------------------|--------------------------|

| | | | |
|--------------------------|---------------------------|--------------------------|-----------------------------|
| <input type="checkbox"/> | Power Locks (if equipped) | <input type="checkbox"/> | Power Windows (if equipped) |
| <input type="checkbox"/> | Power Seats (if equipped) | <input type="checkbox"/> | Key Sensor Buzzer |

